

BTSB T-HANDLE REPLACEMENT INSTRUCTIONS

Replacement Kit P/N: 08867-190A

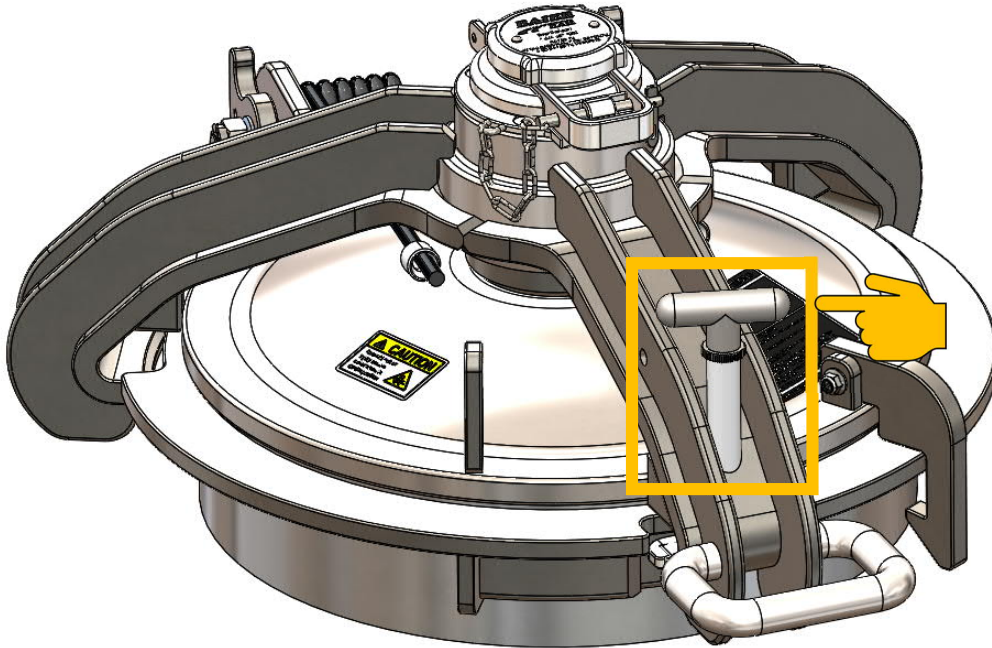

Table of Contents

REPLACEMENT KIT ITEMS	2
TOOLS	3
T-HANDLE ASSEMBLY REPLACEMENT STEPS	5 - 6

T-HANDLE REPLACEMENT KIT:

Each kit comes with three components listed below:

1. The T-Handle replacement assembly x1
2. LOCTITE 242, blue threadlocker 0.02 FL. OZ capsule x1
3. Super Lube multipurpose synthetic lube 1 CC pouch x1

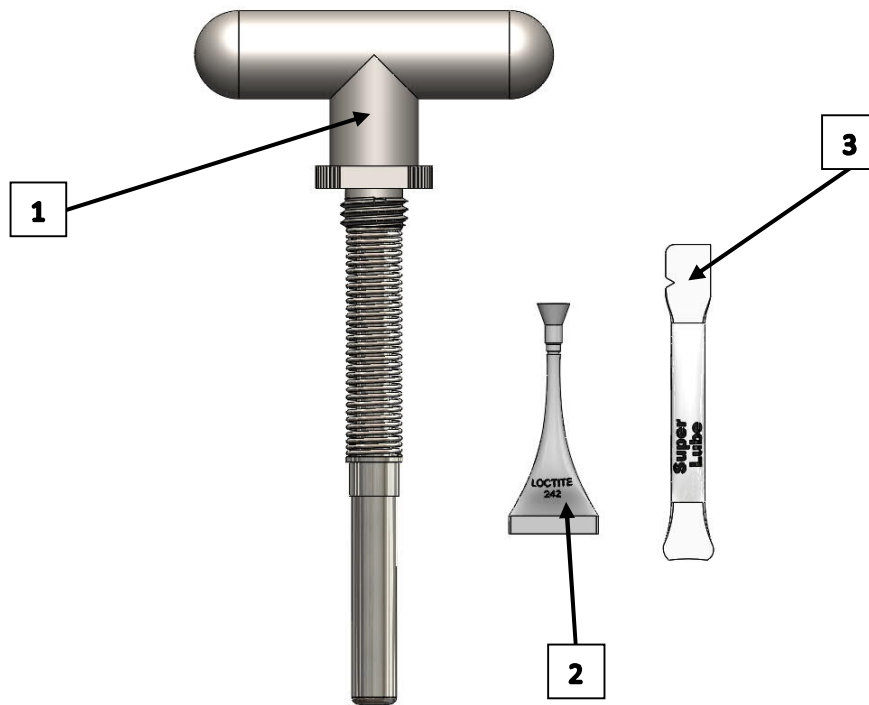

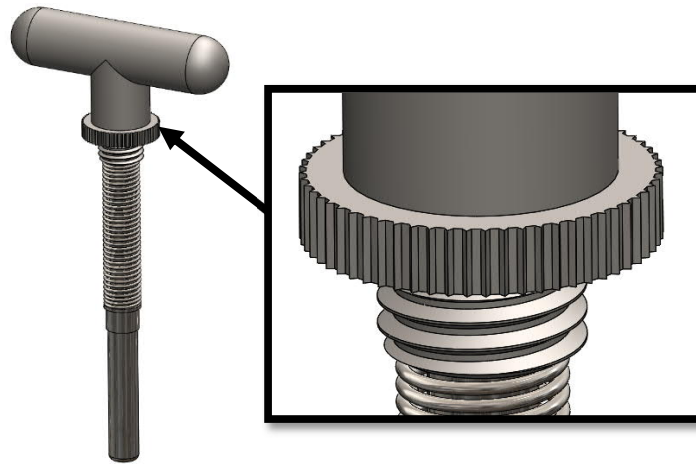

TOOLS REQUIRED (not included with kit):

1. Tongue and groove pliers that will open to 1.50 inches.



2. Small steel brush:



BEFORE REPLACING THE T-HANDLE:



The T-Handle can be replaced with the Manway hatch at either opened or closed position. However, we recommend that you release the Manway cover to the initial open position when replacing the T-Handle. This makes the replacement process easier.

OK

Cover at closed position.

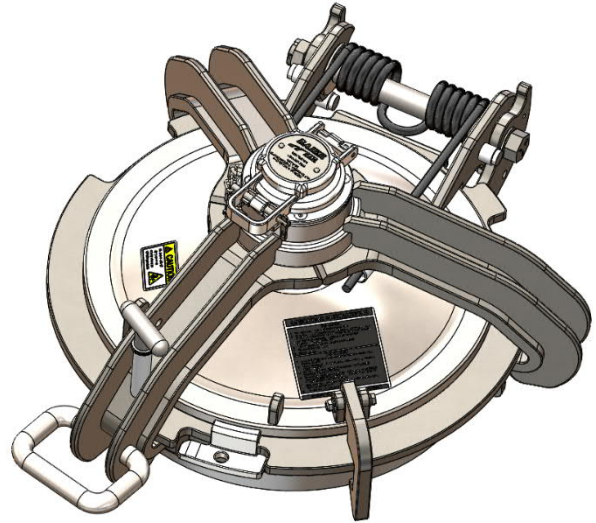
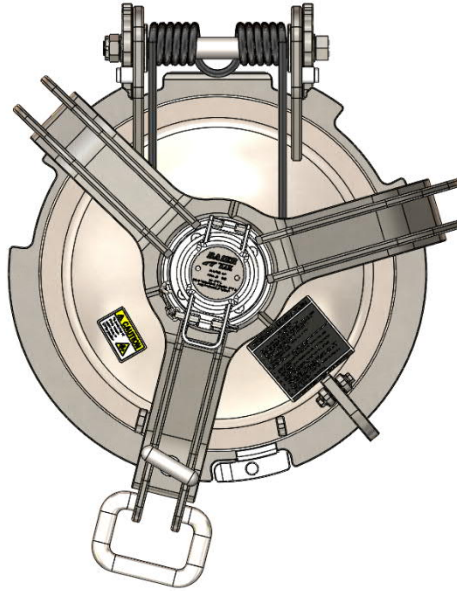

Cover at initial open position.

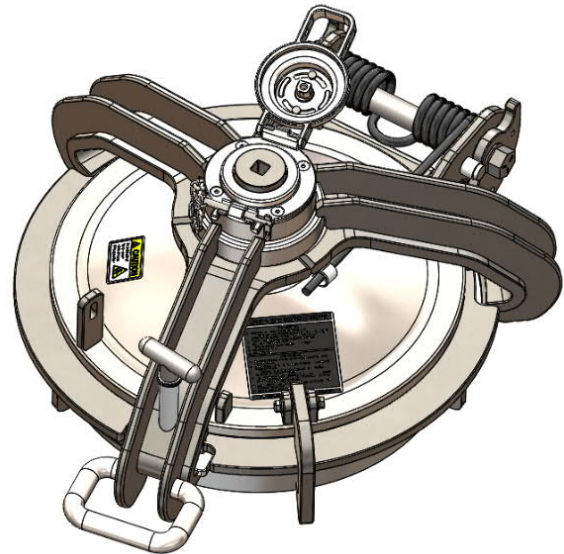
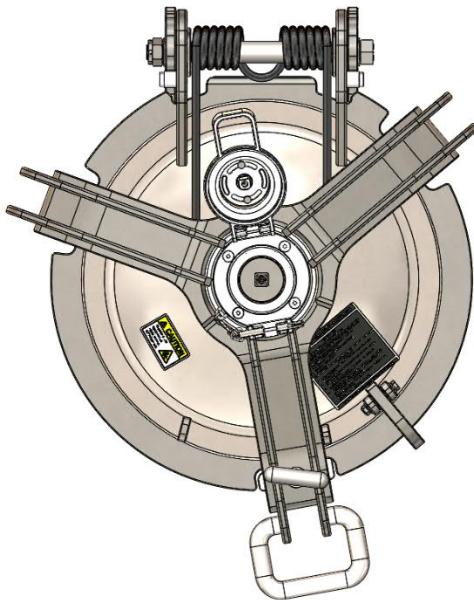

T-HANDLE REPLACEMENT STEPS:

1. With the Manway at the initial open position, use the correct tool and turn the existing shoulder on the Manway hatch counter-clockwise to remove the T-Handle

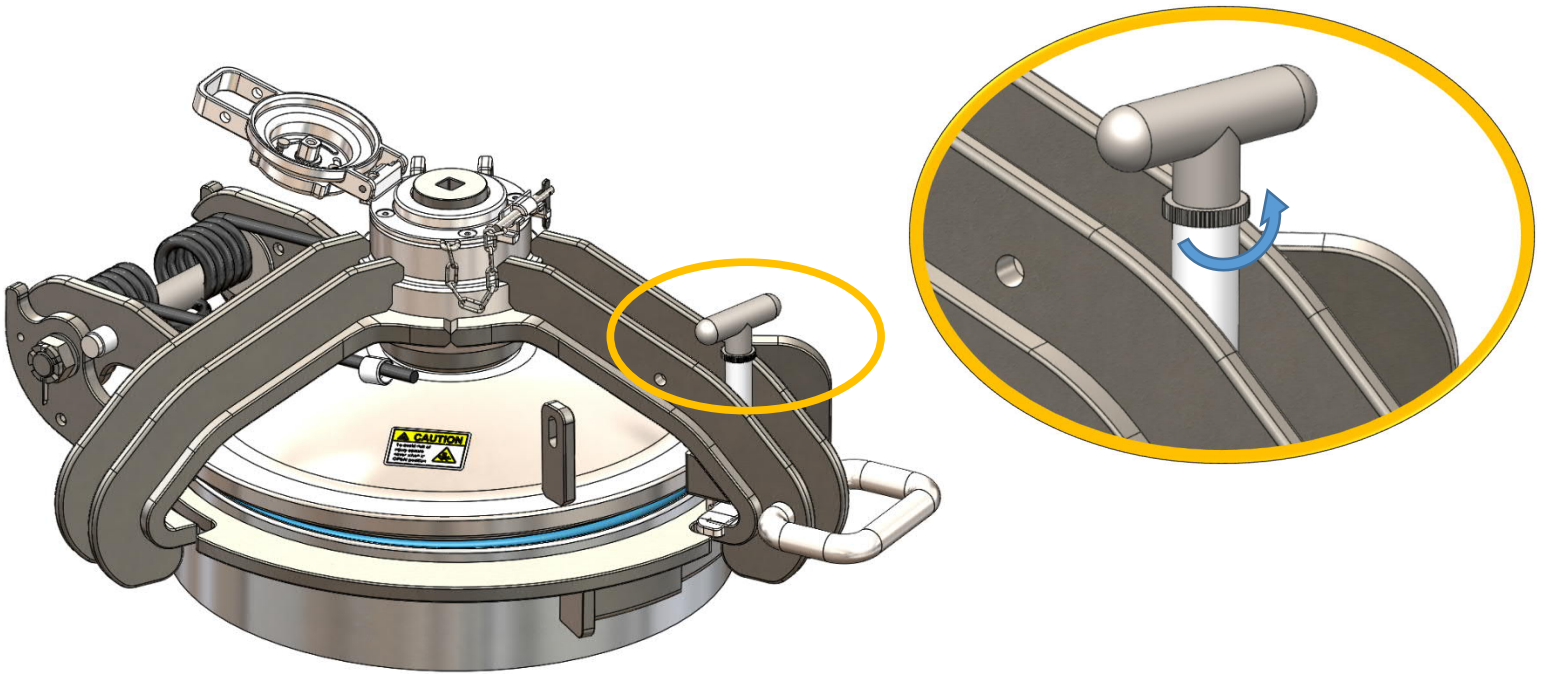

NOTE: THE THREADS ON THE SHOULDERS ARE THREADLOCKED WITH LOCTITE 242 BLUE, YOU MAY EXPERIENCE SOME HARDSHIP WHEN TRYING TO REMOVE THE SHOULDER. USE CAUTION WHEN PERFORMING THIS STEP TO AVOID INJURY OR DAMAGING THE PART.

2. Once the old/damaged T-Handle has been successfully removed, use a small steel brush to clean out the LOCKTITE residuals on the internal threads of the T-Handle housing. Ensure clean threads prior to installing the new T-Handle assembly.

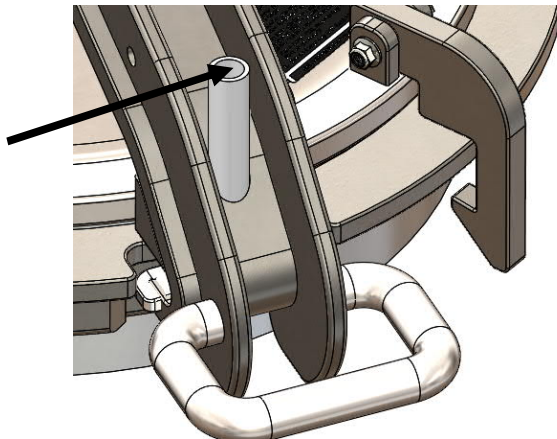

3. Before installing the new T-Handle replacement assembly, make sure the T-Handle is clean and free from debris, especially on the external thread of the shoulder and the spring. Apply the LOCTITE and Super Lube provided with the kit at the areas indicated below:

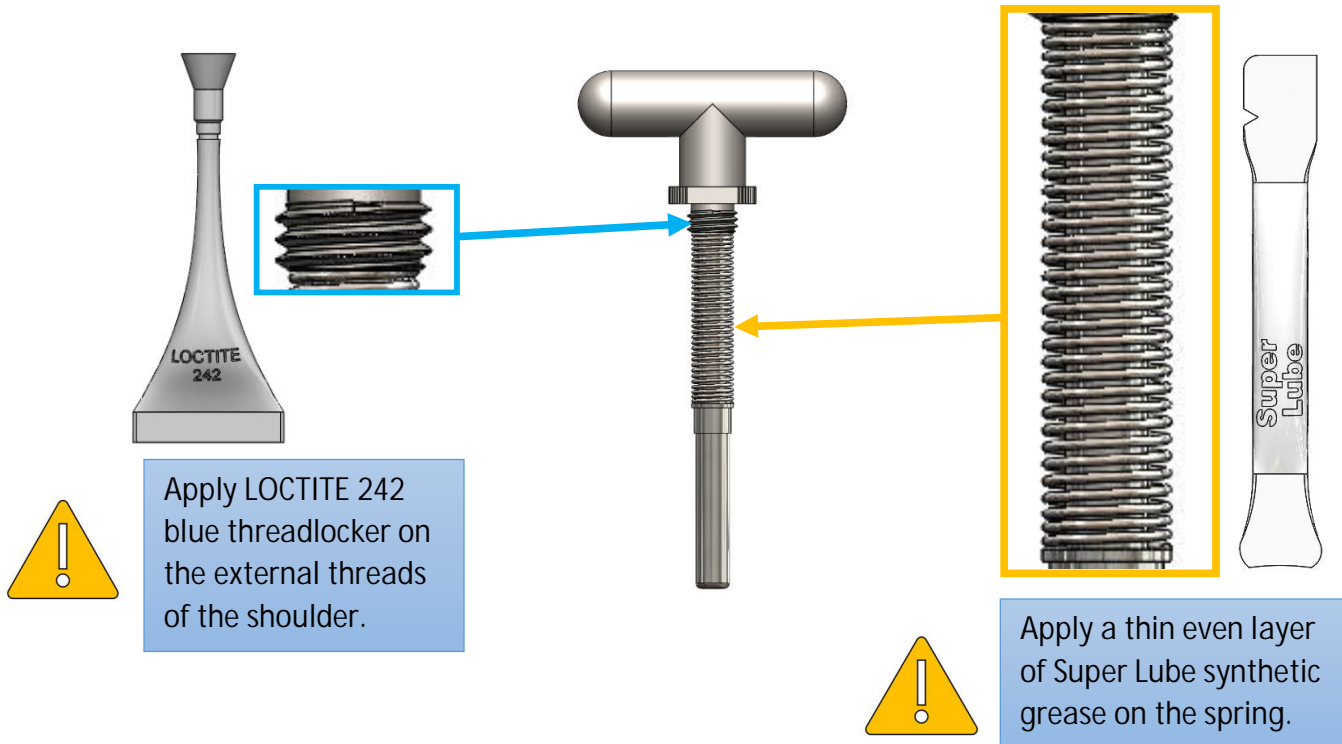

4. Before installing the new T-Handle replacement assembly, ensure both internal threads on housing and external threads on shoulder are clean and free of debris. Insert the new T-Handle into the housing and turn the shoulder clockwise until the shoulder is fully seated on the housing. Since the threads will be secured by the LOCTITE, use the recommended tool to slightly tighten the shoulder (**Do not over tighten**).

With step 4 completed, you have successfully replaced the T-Handle on the Baier Rail Manway Hatch.